



SAEZ

CRANES

H-32

H-32

SR / 2T

DR / 4T OPCIONAL

Montaje
Erection
Montage
Montage
Montaggio

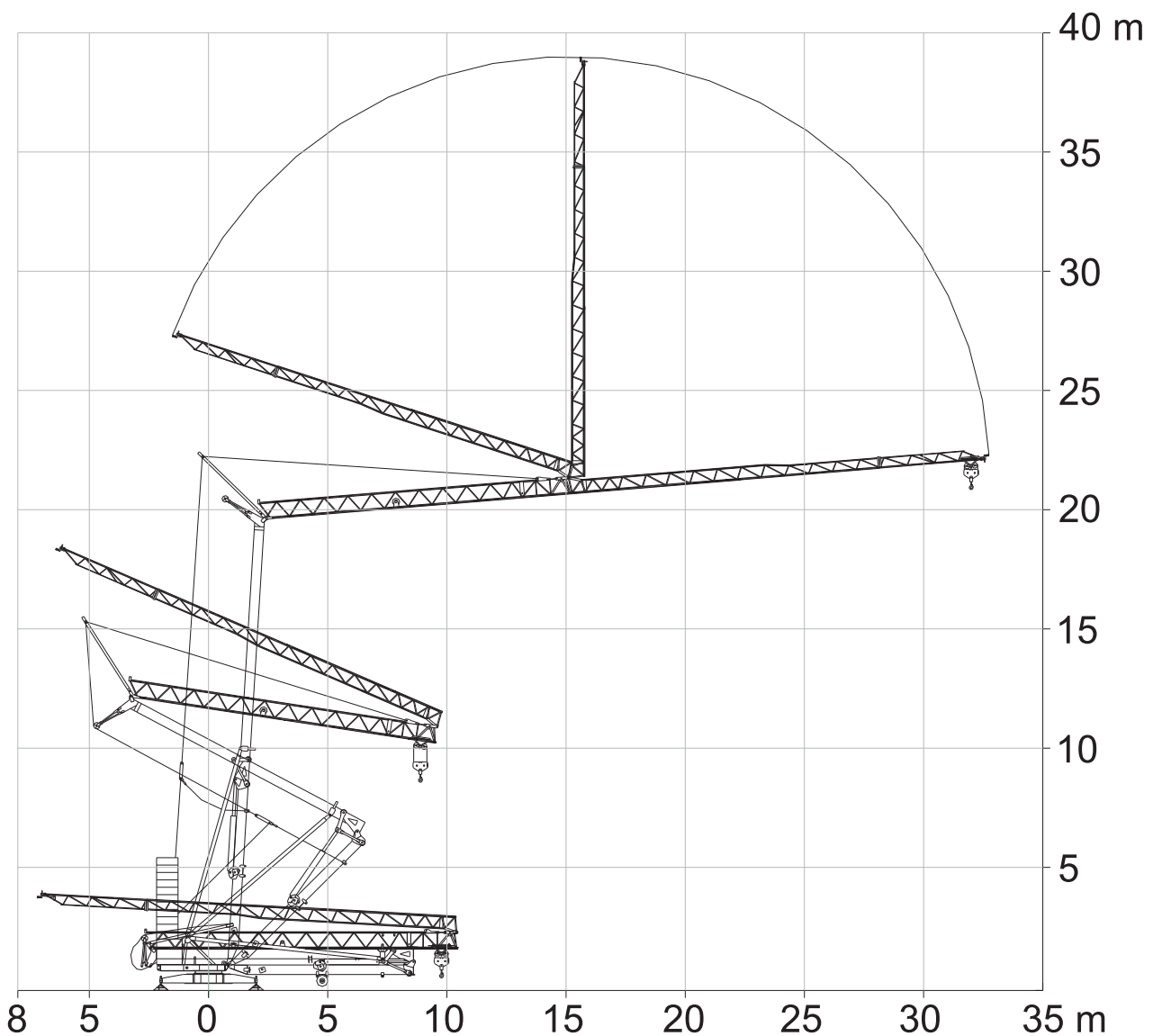

Sky's the limit

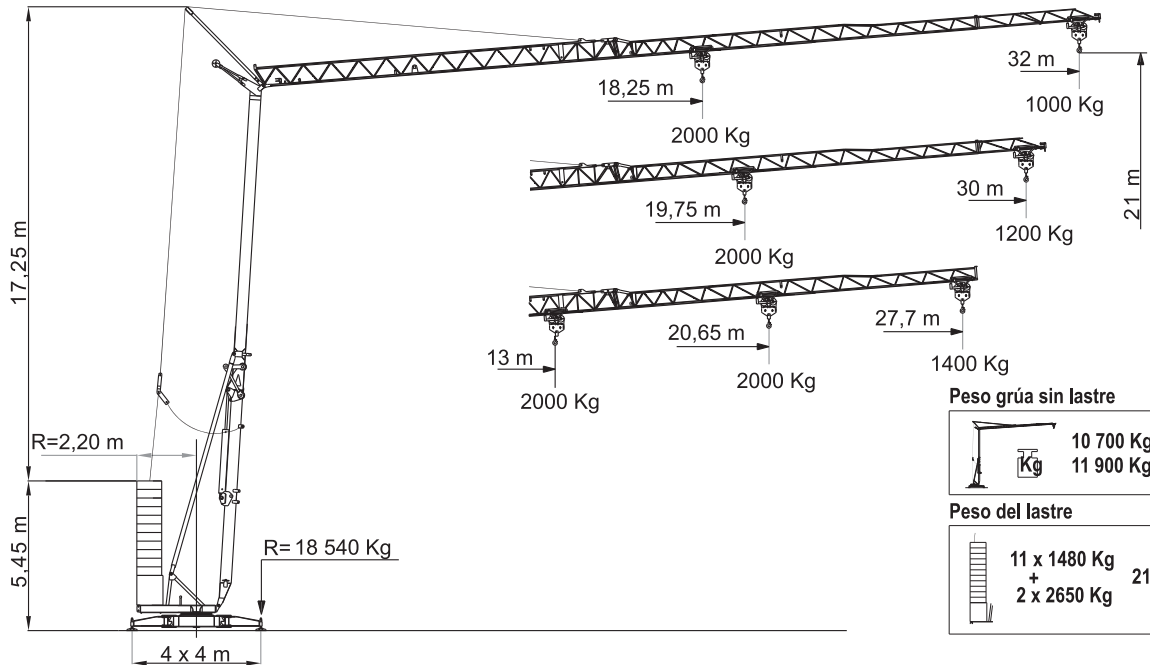
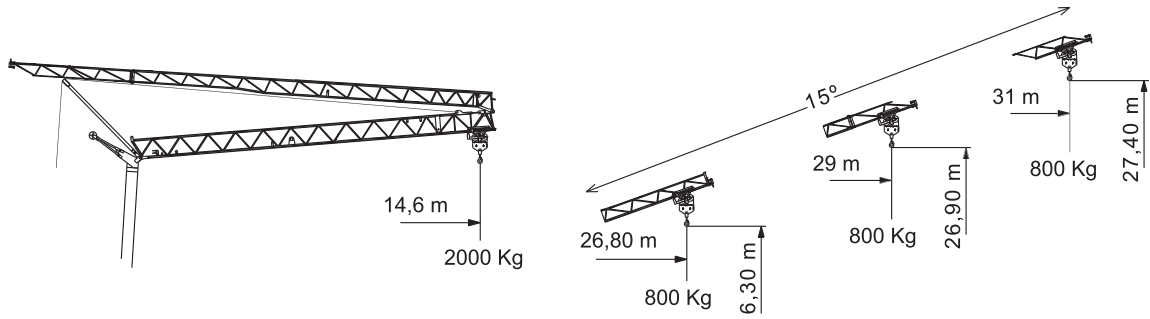

Peso grúa sin lastre

	10 700 Kg SR / 2T
	11 900 Kg DR / 4T

Peso del lastre

	11 x 1480 Kg	21 580 Kg
	+ 2 x 2650 Kg	

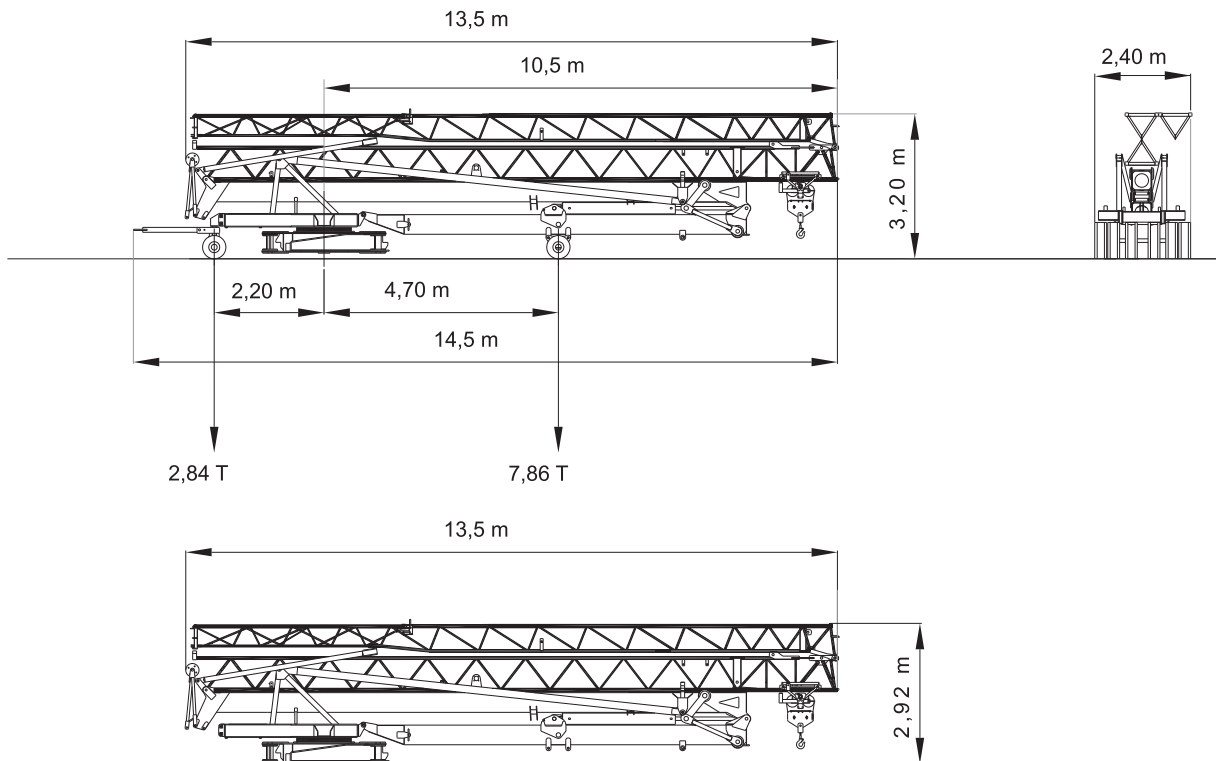

Windzone A-B / DIN 15019
 Viento max. fuerza de servicio 150km/h
 Maximun wind speed out of service 150 km/h
 Maximale windstärke, ohne Betrieb 150 km/h
 Vent maximum, hors service 150 km/h
 Vento max, fuori di servizio 150 km/h



Curvas de cargas
Load diagrams
Lastkurven
Courbes de charges
Curve di carico

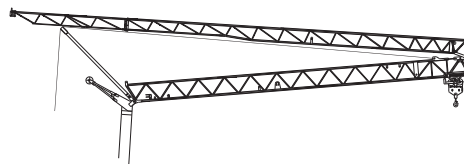

11 x B = 16280 Kg
2 x A = 5300 Kg
21580 Kg

14,6 m
2000 Kg

11 x B = 16280 Kg
2 x A = 5300 Kg
21580 Kg

13,7 m
14,1 m
14,6 m
4000 Kg
3866 Kg
3700 Kg

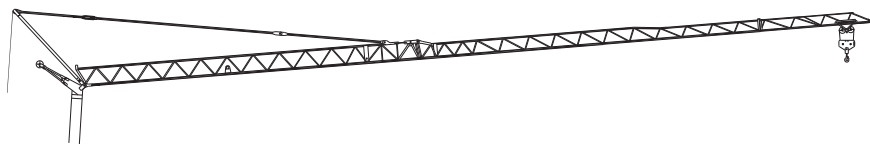

11 x B = 16280 Kg
2 x A = 5300 Kg
21580 Kg

18,25	20	22	24	26	28	30	32	m
2000	1788	1590	1428	1293	1180	1083	1000	Kg

10,5	12	14	16	18	18,25	20	22	24	26	28	30	32	m
4000	3357	2743	2309	1987	1950	1738	1540	1378	1243	1130	1033	950	Kg

19,75	20	22	24	26	28	30	m
2000	1970	1753	1576	1430	1305	1200	Kg

11,3	12	14	16	18	19,75	20	22	24	26	28	30	m
4000	3691	3019	2545	2192	1950	1920	1703	1526	1380	1255	1150	Kg

20,65	22,7	24,7	26,7	27,7	m
2000	1783	1609	1464	1400	Kg

11,75	12,7	14,7	16,7	18,7	20,65	22,7	24,7	26,7	27,7	m
4000	3615	2994	2546	2208	1950	1733	1559	1414	1350	Kg

Flecha izada
Luffing jib
Ausleger in steilstellung
Flèche relevée
Braccio impennato

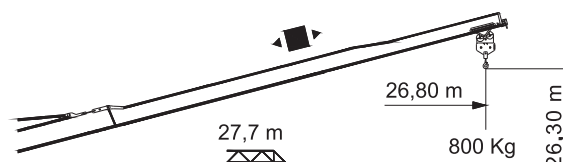
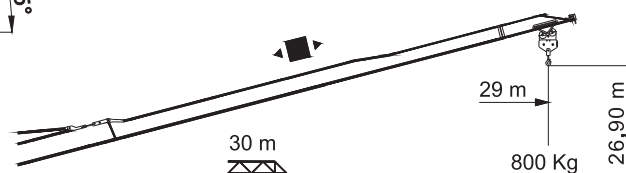
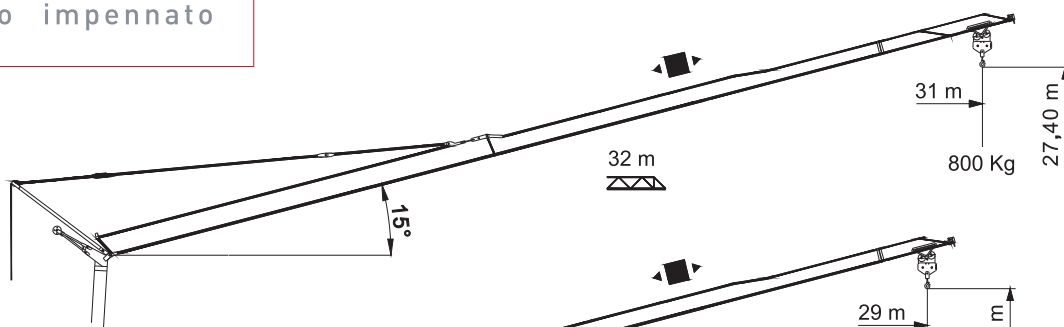







32 m	0	31	m
		800	Kg

30 m	0	29	m
		800	Kg







27,7 m	0	26,80	m
		800	Kg





Mecanismos
Mechanisms
Antriebe
Mécanismes
Meccanismi

10 Hp (7.5Kw) 3V
H.B.G. 21m Ø10mm

							
	m/min	5	20'5	41	2,5	10,25	20,5
	Kg	2000	2000	1000	4000	4000	2000
	Kw	1,8	7,5	7,5	1,8	7,5	7,5
	m/min	19		38	19		38
	Kg	2000		2000	4000		2000
	Kw	1,1		2,2	1,1		2,2
	r.p.m	0,25	0,5	0,8	0,25	0,5	0,8
	N.m	30			30		
	Kw	4			4		

10Hp (7.5Kw)
H.B.G. 21m Ø10mm

							
	m/min	0 → 5	0 → 20'5	0 → 40	0 → 2,5	0 → 10,25	0 → 20
	Kg	2000	2000	1000	4000	4000	2000
	Kw	7,5			7,5		
	m/min	19		45	19		45
	Kg	2000		2000	4000		2000
	Kw	2,2		2,2	2,2		2,2
	r.p.m	0,25	0,5	0,8	0,25	0,5	0,8
	N.m	30			30		
	Kw	4			4		

-  Elevación / Hoisting / Heben / Levage / Sollevamento
-  Distribución / Trolleying / Katzfahren / Distribution / Distribuzione
-  Orientación / Slewing / Schwenken / Orientation / Rotazione
-  Montaje / Erection / Montage / Montage / Montaggio

	400 V 50 Hz	INVERTER 400 V 60 Hz	22 kVA	4x10mm ²
---	----------------	----------------------------	--------	---------------------

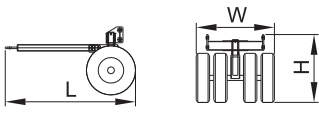
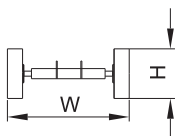
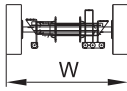
		L (m)	W (m)	H (m)	Kg
Eje de transporte delantero Road transport axle front / Transportachse vorne Essieux de transport avant / Asse di trasporto anteriore		2,05	1,24	1,07	440
Eje de transporte trasero / Road transport axlebehind / Transportachse hinten / Essieux de transport arrière / Asse di trasporto posteriore		0,89	2,40	0,89	346
Eje de transporte trasero con freno Transportachse hinten mit brense Essieux de transport arrière avec frein Asse di trasporto posteriore con freno		1,25	2,40	1,35	700

ESPECIFICACIONES SUJETAS A MODIFICACIONES SIN PREVIO AVISO.

Specifications subject to modification without notice.
Obiges kann ohne berstaendigung geaendert werden.
Specifications susceptibles de modification sans avis préalable.
Specifiche suscettibili di variazioni senza preavviso.

DECLINAMOS TODA RESPONSABILIDAD DERIVADA DE LA INFORMACION PROPORCIONADA.

This information is supplied without liability.
Sämtliche Angaben erfolgen ohne Gewähr.
Ces renseignements sont sans garantie.
Le indicazioni contenute si intendono salvo errori ed omissioni.

SAEZ

CRANES

SAEZ Cranes. Autovía Murcia - San Javier. 30155
Baños y Mendigo . Murcia. Spain
T + 34 968 60 66 00 F + 34 968 60 66 08
saezcranes.com



SAEZ