



SAEZ

CRANES

H-32/28 SR/2T DR/4T OPCIONAL

SR / 2T
DR / 4T OPCIONAL

H-32/28

Selferecting range

Sky's the limit

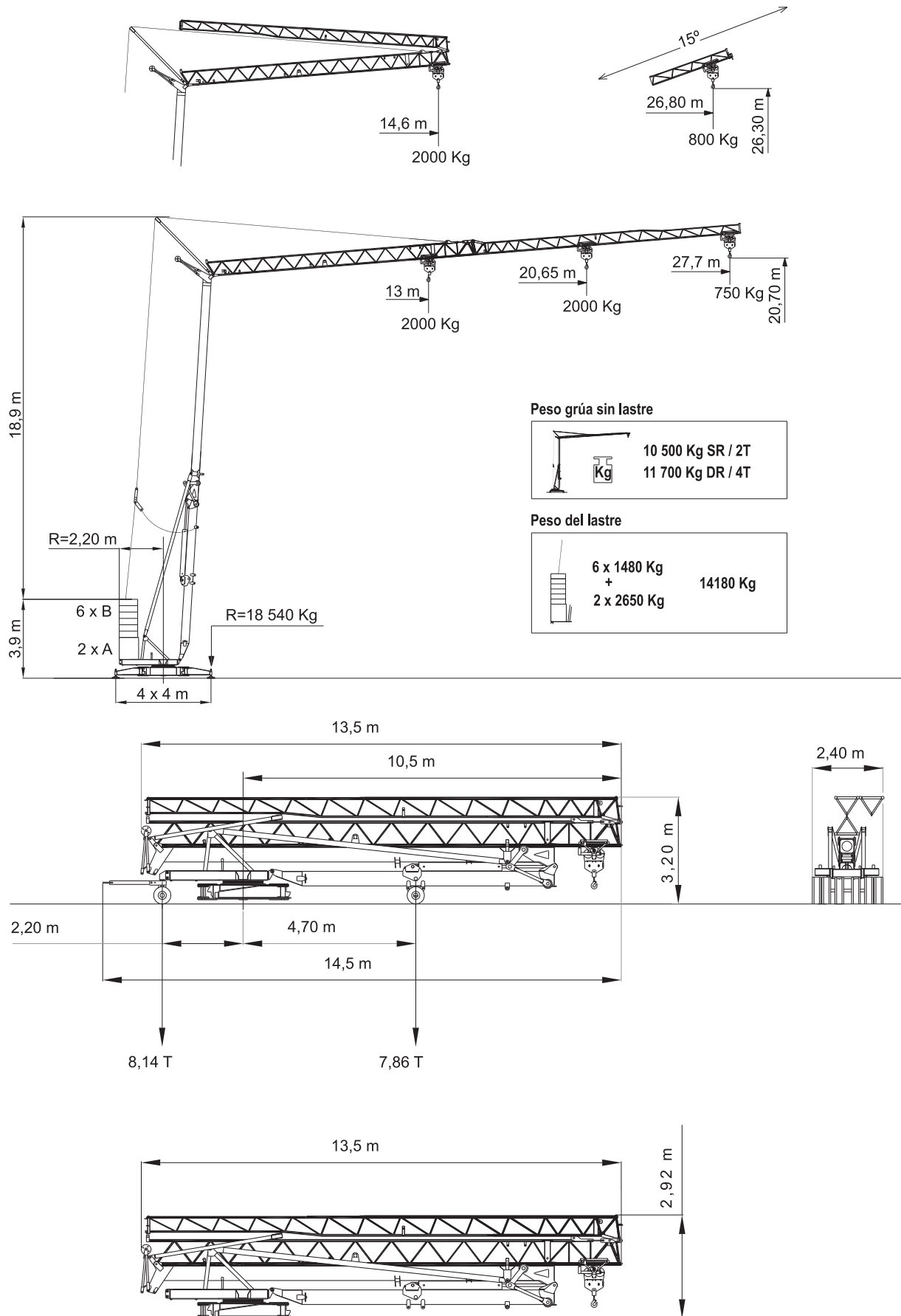

Windzone A-B / DIN 15019
 Viento max. fuerza de servicio 150km/h
 Maximun wind speed out of service 150 km/h
 Maximale windstärke, ohne Betrieb 150 km/h
 Vent maximum, hors service 150 km/h
 Vento max, fuori di servizio 150 km/h

Sáez cranes

H 32-28

Curvas de cargas
Load diagrams
Lastkurven
Courbes de charges
Curve di carico

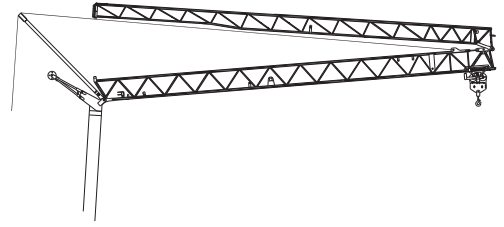

6 x B = 8880 Kg
+
2 x A = 5300 Kg
14180 Kg

14,6 m
2000 Kg



6 x B = 8880 Kg
+
2 x A = 5300 Kg
14180 Kg

8,8	10,6	12,6	14,6
4000	3075	2432	2000

m
Kg

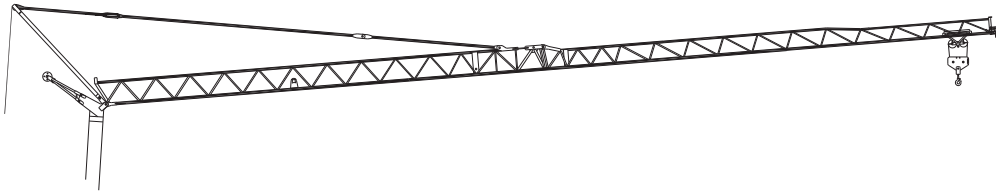

6 x B = 8880 Kg
+
2 x A = 5300 Kg
14180 Kg

13	15,7	17,7	19,7	21,7	23,7	25,7	27,7
2000	1566	1341	1168	1031	920	827	750

m
Kg



7,8	9,7	11,2	13	15,7	17,7	19,7	21,7	23,7	25,7	27,7
4000	2932	2397	1950	1516	1291	1118	981	870	777	700

m
Kg



Flecha izada
Luffing jib
Ausleger in steilstellung
Flèche relevée
Braccio impennato

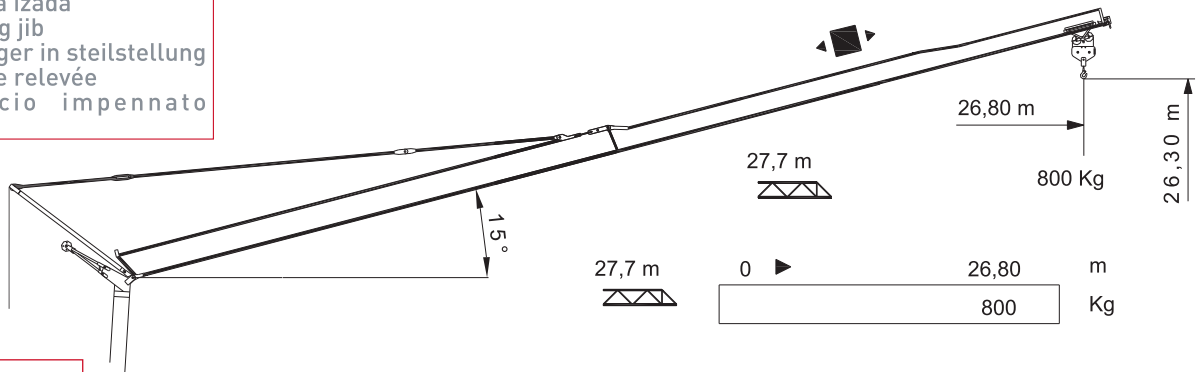

Montaje
Erection
Montage
Montage
Montaggio

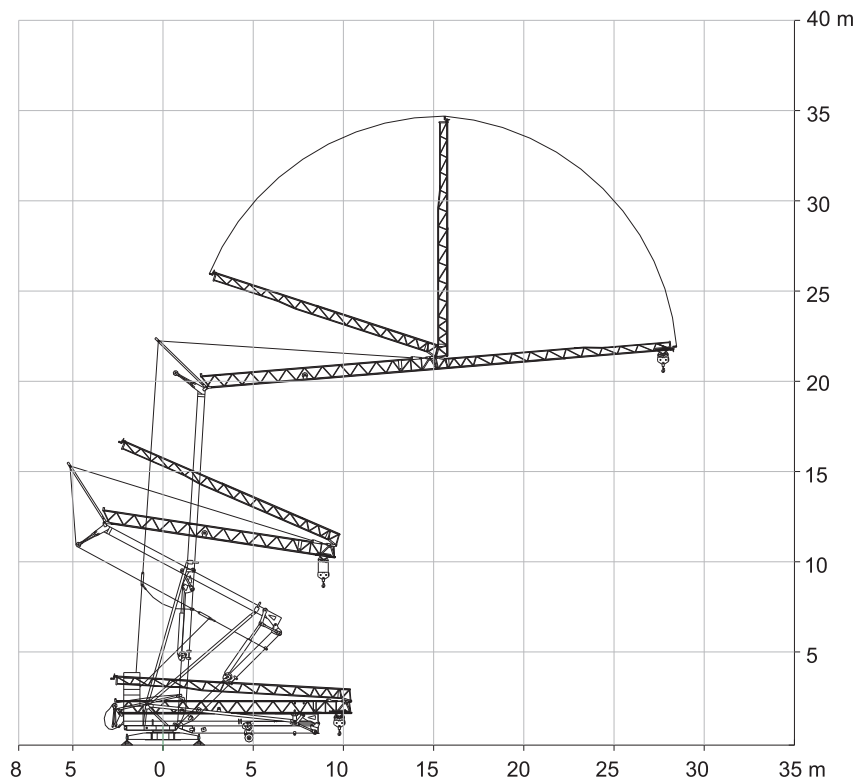

Mecanismos
Mechanisms
Antriebe
Mécanismes
Meccanismi

10 Hp (7.5Kw) 3V H.B.G. 21 Ø10mm							
	m/min	5	20'5	41	2,5	10,25	20,5
	Kg	2000	2000	1000	4000	4000	2000
	Kw	1,8	7,5	7,5	1,8	7,5	7,5
	m/min	19		38	19		38
	Kg	2000		2000	4000		2000
	Kw	1,1		2,2	1,1		2,2
	r.p.m	0,25	0,5	0,8	0,25	0,5	0,8
	N.m	30			30		
	Kw	4			4		

10Hp (7.5Kw) H.B.G. 21 Ø10mm							
	m/min	0 → 5	0 → 20'5	0 → 40	0 → 2,5	0 → 10,25	0 → 20
	Kg	2000	2000	1000	4000	4000	2000
	Kw	7,5			7,5		
	m/min	19		45	19		45
	Kg	2000		2000	4000		2000
	Kw	2,2		2,2	2,2		2,2
	r.p.m	0,25	0,5	0,8	0,25	0,5	0,8
	N.m	30			30		
	Kw	4			4		

- Elevación / Hoisting / Heben / Levage / Sollevamento
- Distribución / Trolleying / Katzfahren / Distribution / Distributions
- Orientación / Slewing / Schwenken / Orientation / Rotazione
- Montaje / Erection / Montage / Montage / Montaggio

	400 V 50 Hz	INVERTER 400 V 60 Hz	22 kVA	4x10mm ²
--	----------------	----------------------------	--------	---------------------

	L (m)	W (m)	H (m)	Kg		
Eje de transporte delantero Road transport axle front / Transportachse vorne Essieux de transport avant / Asse di trasporto anteriore			2,05	1,24	1,07	440
Eje de transporte trasero / Road transport axlebehind / Transportachse hinten / Essieux de transport arrière / Asse di trasporto posteriore			0,89	2,40	0,89	346
Eje de transporte trasero con freno Transportachse hinten mit bremsen Essieux de transport arrière avec frein Asse di trasporto posteriore con freno			1,25	2,40	1,35	700

ESPECIFICACIONES SUJETAS A MODIFICACIONES SIN PREVIO AVISO.

Specifications subject to modification without notice.
 Obiges kann ohne berstaendigung geaendert werden.
 Specifications susceptibles de modification sans avis préalable.
 Specifiche suscettibili di variazioni senza preavviso.

DECLINAMOS TODA RESPONSABILIDAD DERIVADA DE LA INFORMACION PROPORCIONADA.

This information is supplied without liability.
 Sämtliche Angaben erfolgen ohne Gewähr.
 Ces renseignements sont sans garantie.
 Le indicazioni contenute si intendono salvo errori ed omissioni.

SAEZ

CRANES

SAEZ Cranes. Autovía Murcia - San Javier. 30155
Baños y Mendigo . Murcia. Spain
T + 34 968 60 66 00 F + 34 968 60 66 08
saezcranes.com



SAEZ